

Thread Whirling



Features

WATCH ON
New Double-lead video is on [YouTube](#)



- NTK's unique patented design technology makes precise and correct inserts possible the first time, *without any redesign or remanufacturing even if it is a multiple-lead thread*
- The sharper cutting edges produce a better surface finish and longer tool life than competitor's inserts

Form Double-lead or Multiple-lead with Single Pass

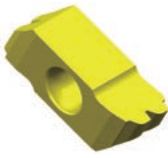
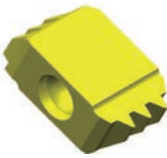
	Double-lead threads	Triple-lead threads
Work	Bone screw	Worm gear
Work material	Ti-6Al-4V ELI	brass
Work appearance		
Insert appearance		
Major Dia.	φ 4.0mm	φ 7.0mm
Minor Dia.	φ 2.4mm	φ 4.7mm
Lead [Pitch×No. of Lead]	3.42mm (1.71mm×2)	4.9mm (1.63mm×3)

- Can reduce cycle time by more than half
- NTK can achieve what other competitors cannot

Double-lead Bone Screw Process Example

- 1 1st thread whirl at taper part
- 2 Rotate the bar 180° and whirl the 2nd thread on same part as **1**
- 3 Thread whirl whole straight part
- 4 Thread whirl at very last part to get two-exits, after back of bar has been backed up a half lead (one pitch) and rotated 180°

Special Item Capability

- Even though almost all bone screw shapes are special, NTK thread whirling inserts can make the correct shape of thread the first time, without any redesign or remanufacturing
- Basically NTK thread whirling inserts are ground with topping and coated

Recommended Cutting Conditions

No. of teeth		9	6	4	
Conditions					
Main spindle	RPM	10 - 40	10 - 25	7 - 15	Faster RPM reduces machining time
Whirling cutter	RPM	1500 - 4000			
Feed Rate		Same as thread-lead			
Bar stock	φ	~φ10.0 *		~φ5.0	* For cutter with φ12mm ID
Work Material		Ti-6Al-4V ELI / SUS316 / Titanium			

- Formula for calculating thread whirling process time

$$T \text{ (Seconds)} = \frac{60 \times \text{Thread length}}{\text{Main spindle rpm} \times \text{Feed rate (Thread lead)}}$$

Ex.) Double lead / 50mm length / 2.54 lead (2×1.27 pitch) / 30 rpm

$$T \text{ (Seconds)} = \frac{60 \times 50}{30 \times 2.54} = 40 \text{ Seconds}$$

Applicable Thread Geometry (Approximated)

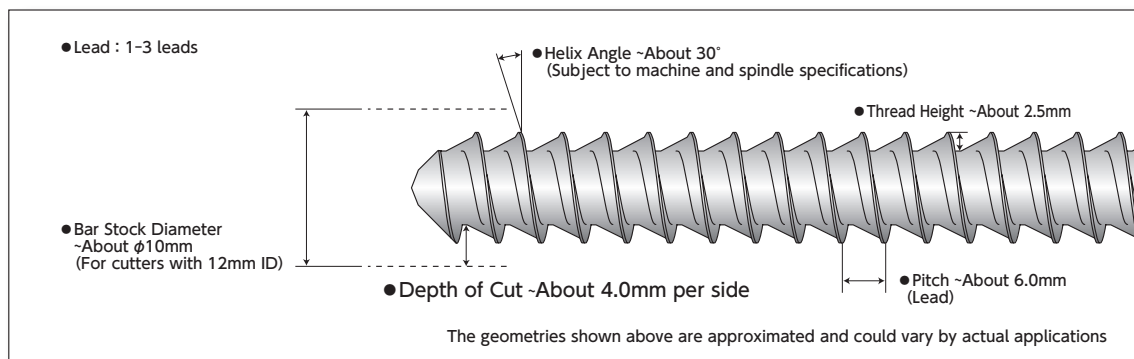

Thread Whirling System



Type 1

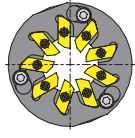
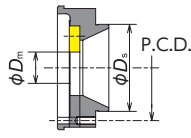

Type 2
Quick-change

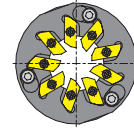
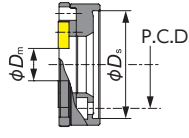

Type 3
Quick-change

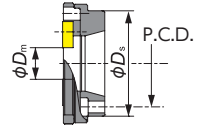

Machine make	Model	Location	Spindle make	Spindle model	Helix angle	NTK Thread whirling system	Stock	No. of tooth	ϕD_m (mm)	Type	ϕD_s	P.C.D.	Mount adapter bolt																	
CITIZEN	M-32-VIII	Gang	CITIZEN	BTW-4000	0° - 15°	TWC9C0746HP1	●	9	$\phi 12$	1	$\phi 46$	$\phi 35$	M3																	
	L20/L20E/L20X	Gang		BTW-3000 BTW-3100	0° - 15°																									
	L32/L32X	Gang		BTW-3100	0° - 15°																									
	D25			BTW-6000	±25°																									
	L32X			BTW-5000	±25°																									
	L20X				0° - 15°																									
	M16			BTW-2000	±25°																									
	A20																													
	A32																													
	L20/L20X																													
	L32/L32X																													
	M20																													
	M32																													
	C32			BTW-1000	±25°																									
	L20																													
	M20																													
	M-32						+20° - -25°																							
							±25°																							
	C12/16			Gang	CITIZEN	LTR0170	±15°	TWC9C1037P2	●	9	$\phi 12$	2	$\phi 37$	$\phi 30.5$	CS0310(M3)															
	M12/16	Turret		LTR0128/LTR0168																										
M12/16III	MSW105																													
M20/32III	Gang	KSW110	±15°	TWC9J1040P2			9	$\phi 12$	2	$\phi 40$	$\phi 32.5$	H-M4 × 12																		
L20		LTR0183																												
M20/32		LTR0169																												
M20/32	Turret	PCM	GSW-101	±15°	TWC6P1620HP1-D9		6	$\phi 9$	1	$\phi 32$	$\phi 26$	M4 (Provided with spindle)																		
K16	Attachment		LSW-101-L20	±10°	TWC9P1340P2	●	9	$\phi 12$	2	$\phi 40$	$\phi 32.5$	M4 (Provided with spindle)																		
L20	Gang		MSW-101																											
M12/16	Turret		KSW-101																											
M20/M32																														
STAR	SW-12	Attachment	STAR	10159	±20°	TWC4S1433HP1	●	4	$\phi 8$	7	$\phi 38$	$\phi 27$	CS0310(M3)																	
	ECAS-12/20			54178	±10°																									
	SB-20R			0M171	-20° - 0°																									
	SR-20J/20R III 20R IV/32J II			68172	-20° - 0°																									
	SR-38			10172	±10°																									
	ECAS-20T	59172		-20° - 0°	TWC9S1640P2									●	9	$\phi 12$	3	$\phi 40$	$\phi 33$	CS04148S(M4)										
	ECAS-32T	58171		±20°																										
	ST-38	43156		±20°																										
	SV-12	45172		±10°																										
	SV-20/SV-20R	42173		±10°																										
	SV-32	43172		±10°																										
	SV-38R	43156		±20°																										
	BH20/BH38	Turret		TSUGAMI																	3263-Y481	±10°	TWC9TS2252P2	●	9	$\phi 12$	3	$\phi 52$	$\phi 42$	CS0515(M5)
	BS20	Attachment																			3214-Y1371	±10°	TWC9TS20550P2		9	$\phi 16$	3	$\phi 50$	$\phi 40$	CS0515(M5)
SS20/SS26/SS32 B0265/B0266-II B0325/B0326-II	Attachment	TSUGAMI	3268-Y450 3268-Y451		0° - 10°	TWC9TS2244HP1	●	9	$\phi 12$	4	$\phi 52$	$\phi 44$	CS0520(M5)																	
S205/S206			3281-Y450 3281-Y451		0° - 20°	TWC9TS1944HP1	●	9	$\phi 12$	4	$\phi 52$	$\phi 44$	CS0520(M5)																	
B0123/B0124/B0125/ B0126-II/III B0203/B0204/B0205/ B0205/B0206-II/III			3220-Y6540 3220-Y6541		0° - 25°	TWC9TS1644HP1	●	9	$\phi 12$	4	$\phi 52$	$\phi 44$	CS0515(M5)																	
SS20/SS26/SS32			3268-Y271		0° - 30°	TWC9TS1044HP1	●	9	$\phi 12$	4	$\phi 52$	$\phi 44$	CS0515(M5)																	
					0° - 10°	TWC9TS1952P2BK		9	$\phi 12$	4	$\phi 52$	$\phi 38$	CS0515(M5)																	
					0° - 20°	TWC9TS1652P2BK		9	$\phi 12$	4	$\phi 52$	$\phi 38$	CS0515(M5)																	
SS207/SS267/SS327			-		Using B-axis		0° - 15°	TWC4TS3010HP1	●	4	$\phi 7$	5	$\phi 10$	For single-corner inserts only																

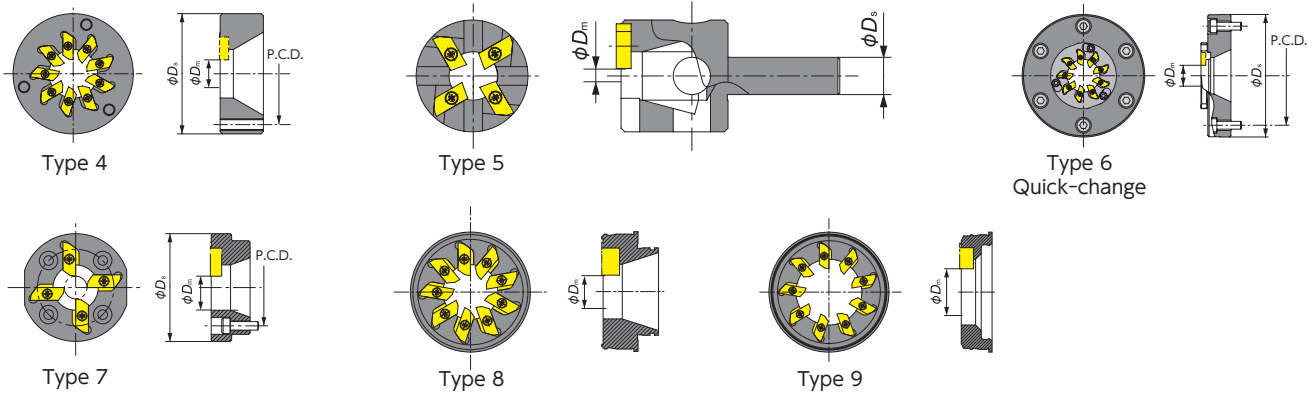

Machine make	Model	Location	Spindle make	Spindle model	Helix angle	NTK Thread whirling system	Stock	No. of tooth	ϕD_m (mm)	Type	ϕD_s	P.C.D.	Mount adapter bolt
TORNOS	DECO 10/10a	Attachment	TORNOS	224-1900	$\pm 15^\circ$	TWC6TO11542HP1		6	$\phi 12$	4	$\phi 42$	$\phi 32$	CS0410(M4)
	Evo DECO 10/10			242-1900									
	DECO 13a/13e			226-1900									
	Evo DECO 16/10			243-1900									
	Swiss ST26			246-1900	$\pm 15^\circ$	TWC9TO10540P2		9	$\phi 12$	3	$\phi 40$	$\phi 31$	CS0410(M4)
	DECO 20a			223-1900									
	DECO 26a			225-1900									
	Sigma 20			234-2750									
Sigma 32	236-2750	$\pm 25^\circ$	TWC9TO12050P2-D18		9	$\phi 18$	3	$\phi 50$	$\phi 40$	CS0410(M4)			
HASEGAWA	JS-1W	—	HASEGAWA	—	$0^\circ - 20^\circ$	TWC9HA22594P2		9	$\phi 16$	6	$\phi 94$	$\phi 76$	CS0620(M6)
Various Machines			WTO	42BJ	-22° ^{※1}	TWC9WT42BJ20D12RH ^{※2}		9	$\phi 12$	8	—	—	—
				54BJ	30°	TWC9WT54BJ30D12RH ^{※2}		9	$\phi 12$	9	—	—	—
					30°	TWC9WT54BJ25D22RH ^{※2}		9	$\phi 22$	9	—	—	—

※1 Would be changed by spindle
 ※2 Designed for 6.5mm thickness inserts

■ Spare Insert Holder (Cartridge)

Item number	No. of tooth	ϕD_m (mm)	Compatible cutters
TWC6HP2	6	12	For Type 2 and Type 3*
TWC9HP2	9	12	For Type 2 and Type 3*
TWC9HP2-D16	9	12	For Type 6

Note: Insert holder comes with insert screws and wrench
 Insert holder mounting screw is not included
 *Cannot be used for TWC9TS20550P2, TWC9TO12050P2-D18 and TWC9HA22594P2

■ Spare Parts

Description		Item number
Insert Screw	For 4mm thick inserts	FSI17-2.2×6.0
	For 6.5mm thick inserts	FSI24-2.2×7.9
Wrench		T-07
Insert Holder Mounting Bolt		CS0309-TW

NTK's Unique Attachment System

NTK's whirling insert holder can be attached and detached without removing mounting screws

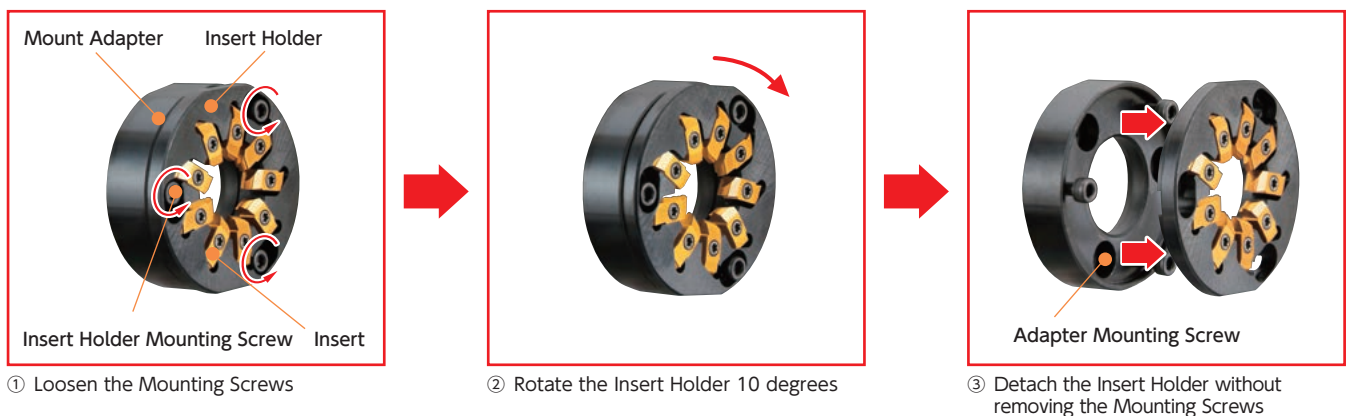

Basic Insert Grade

ZM3

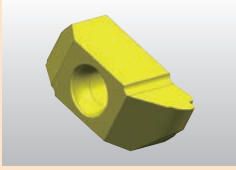

- ZM3 is our basic grade for NTK thread whirling
- ZM3 offers excellent surface finish
- NTK can make inserts with other coatings to meet customers demands

NTK Experiences and Solutions Example

For absolute flat on OD

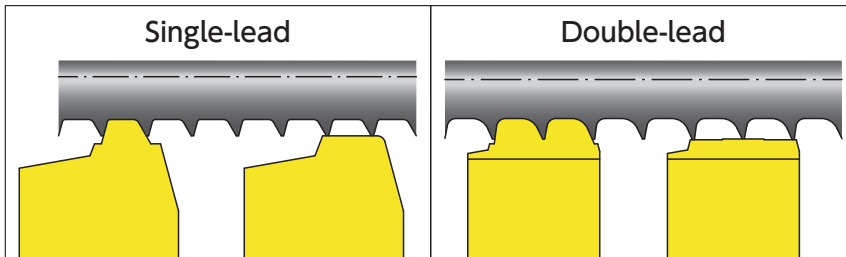

- Two insert combination brings absolute flat on OD to meet the drawing

For tiny thread

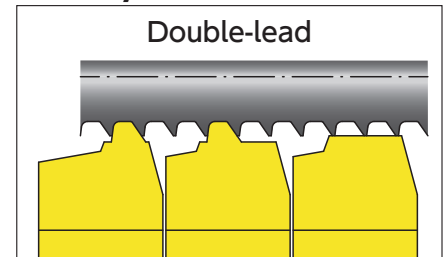

- NTK's Thread Whirling system can machine small diameter multi-lead screws to spec, with lower tool pressure, by using several types of specially designed and accurately ground inserts on the cutter.

Standard Thread Whirling Inserts (two-sided) for Medical ISO Style Threads

4mm thickness insert

(Note: Must use Thread whirling cutters with 12mm ϕ Dm dimension. See page U18-19 to find ϕ Dm for each cutter.)

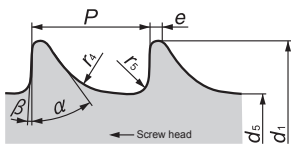

ISO5835 HA

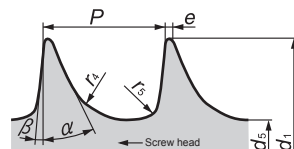

ISO5835 HB

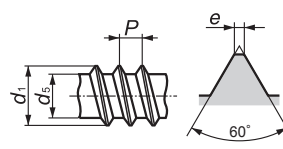

ISO9268 HC

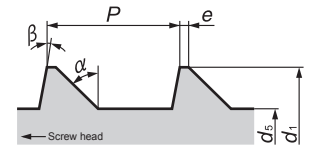

ISO9268 HD

Item number	ISO Standard	d_1	d_5	P	e	r_4	r_5	α	β	Metric dimensions		
										Supposition material Dia.	Coated Carbide	
TW5835-HA1.5-D12	ISO5835	HA1.5	1.5 ⁰ _{0.15}	1.1 ⁰ _{0.1}	0.5	0.1	0.3	0.1	35°	3°	ϕ 8	●
TW5835-HA2.0-D12		HA2.0	2.0 ⁰ _{0.15}	1.3 ⁰ _{0.1}	0.6	0.1	0.4	0.1	35°	3°		●
TW5835-HA2.7-D12		HA2.7	2.7 ⁰ _{0.15}	1.9 ⁰ _{0.15}	1	0.1	0.6	0.2	35°	3°		●
TW5835-HA3.5-D12		HA3.5	3.5 ⁰ _{0.15}	2.4 ⁰ _{0.15}	1.25	0.1	0.8	0.2	35°	3°		●
TW5835-HA4.0-D12		HA4.0	4.0 ⁰ _{0.15}	2.9 ⁰ _{0.15}	1.5	0.1	0.8	0.2	35°	3°		●
TW5835-HA4.5-D12		HA4.5	4.5 ⁰ _{0.15}	3.0 ⁰ _{0.15}	1.75	0.1	1	0.3	35°	3°		●
TW5835-HA5.0-D12		HA5.0	5.0 ⁰ _{0.15}	3.5 ⁰ _{0.15}	1.75	0.1	1	0.3	35°	3°		●
TW5835-HB4.0-D12	ISO5835	HB4.0	4.0 ⁰ _{0.15}	1.9 ⁰ _{0.15}	1.75	0.1	0.8	0.3	25°	5°	ϕ 8	●
TW5835-HB6.5-D12		HB6.5	6.5 ⁰ _{0.15}	3.0 ⁰ _{0.15}	2.75	0.2	1.2	0.8	25°	5°	ϕ 10	●
TW9268-HC2.9-D12	ISO9268	HC2.9	2.79 to 2.9	2.03 to 2.18	1.06	0.1max	—	—	—	—	ϕ 8	
TW9268-HC3.5-D12		HC3.5	3.43 to 3.53	2.51 to 2.64	1.27	0.1max	—	—	—	—		
TW9268-HC3.9-D12		HC3.9	3.78 to 3.91	2.77 to 2.92	1.27	0.1max	—	—	—	—		
TW9268-HC4.2-D12		HC4.2	4.09 to 4.22	2.95 to 3.25	1.27	0.1max	—	—	—	—		
TW9268-HD4.0-D12		HD4.0	4.0±0.03	2.92±0.03	1.59	0.1	—	—	45°	10°		
TW9268-HD4.5-D12		HD4.5	4.5±0.03	2.92±0.03	2.18	0.1	—	—	45°	10°		

Application Examples

Double-lead Bone Screw			
Work Material : Ti-6Al-4v ELI			
Bar Stock Dia.	φ9.5	Number of start	2
Major Dia.	φ4.0	Helix Angle	28.5°
Minor Dia.	φ2.5	Hand of thread	Right
Cutting condition			
Main Spindle Speed (rpm)	15	Speed of whirling cutter (rpm)	3,500
Lead = Feed (mm/rev)	5.5	Result	OK
NTK Thread Whirling		Dramatically improved productivity	
Competitor's Thread Whirling		Cannot complete with single pass. Requires feeding stock multiple times and two passes for threading each time.	
NTK thread whirling succeeded in double lead screw machining when one of the major thread whirling suppliers has failed many times.			

Double-lead Bone Screw			
Work Material : Ti-6Al-4v ELI			
Bar Stock Dia.	φ8.9	Number of start	2
Major Dia.	φ4.57	Helix Angle	23.0°
Minor Dia.	φ3.05	Hand of thread	Right
Cutting condition			
Main Spindle Speed (rpm)	12	Speed of whirling cutter (rpm)	2,500
Lead = Feed (mm/rev)	5.08	Result	OK
NTK Thread Whirling		Dramatically improved productivity	
Competitor's Thread Whirling		Cannot complete with single pass. Requires feeding stock multiple times and two passes for threading each time.	
The customer could not get perfect double lead thread form in single pass from other manufacturers. NTK got perfect thread form with a single pass on first trial saving cycle time.			

Double-lead Bone Screw			
Work Material : Ti-6Al-4v ELI			
Bar Stock Dia.	φ6.35	Number of start	2
Major Dia.	φ3.0	Helix Angle	15.4°
Minor Dia.	φ2.1	Hand of thread	Right
Cutting condition			
Main Spindle Speed (rpm)	11	Speed of whirling cutter (rpm)	2,200
Lead = Feed (mm/rev)	2.2	Result	OK
NTK Thread Whirling		Dramatically improved productivity	
Competitor's Thread Whirling		Cannot complete with single pass. Requires feeding stock multiple times and two passes for threading each time.	
Customer was concerned with stock rigidity and long cycle time. NTK applied three geometry inserts to achieve single pass machining, in dramatically short time. The up-sharp cutting edges and low cutting pressure produced "excellent" surface finish.			

Single-lead Bone Screw			
Work Material : 316SS			
Bar Stock Dia.	φ8.0	Number of start	1
Major Dia.	φ3.45	Helix Angle	7.5°
Minor Dia.	φ2.67	Hand of thread	Right
Cutting condition			
Main Spindle Speed (rpm)	23	Speed of whirling cutter (rpm)	2,000
Pitch = Feed (mm/rev)	1.24	Result	OK
NTK Thread Whirling		2600 pcs	
Competitor's Thread Whirling		1000 pcs	
Some thread whirling manufacturers offer 6-teeth or 12-teeth systems, too many teeth cause chip packing issues and more tool pressure. Fewer teeth means greater cycle time. NTK concluded that 9-teeth is the best configuration. Our customers can run 1.5 times faster and get longer tool life.			

Single-lead Bone Screw			
Work Material : Ti-6Al-4v ELI			
Bar Stock Dia.	φ5.0	Number of start	1
Major Dia.	φ2.3	Helix Angle	5.3°
Minor Dia.	φ1.7	Hand of thread	Right
Cutting condition			
Main Spindle Speed (rpm)	30	Speed of whirling cutter (rpm)	3,100
Pitch = Feed (mm/rev)	0.58	Result	OK
NTK Thread Whirling		2200 pcs	
This thread is up to 32 mm length with a small pitch. Cycle time could be increased with a single-point threading tool. NTK's inserts, designed for lower tool pressure, ran 2,200 pcs/corner at 30 rpm of bar stock (F10,800). It only took 110 seconds to finish a 32 mm length thread.			

Triple-lead Worm Gear			
Work Material : Brass			
Bar Stock Dia.	φ8.0	Number of start	3
Major Dia.	φ7.0	Helix Angle	14.6°
Minor Dia.	φ4.7	Hand of thread	Left
Cutting condition			
Main Spindle Speed (rpm)	20	Speed of whirling cutter (rpm)	3,500
Lead = Feed (mm/rev)	4.8	Result	OK
Multi-lead threads, common in the Worm Gear industry are made by a forming or cutting process. The large helix angle is difficult to machine with single-point threading. NTK now makes thread whirling inserts for multi-lead threads. Cycle time is reduced with a one pass process and thread form dimensions are stable with the low tool pressure.			