

DS Holder Series

For back machining | CNC automatic lathes

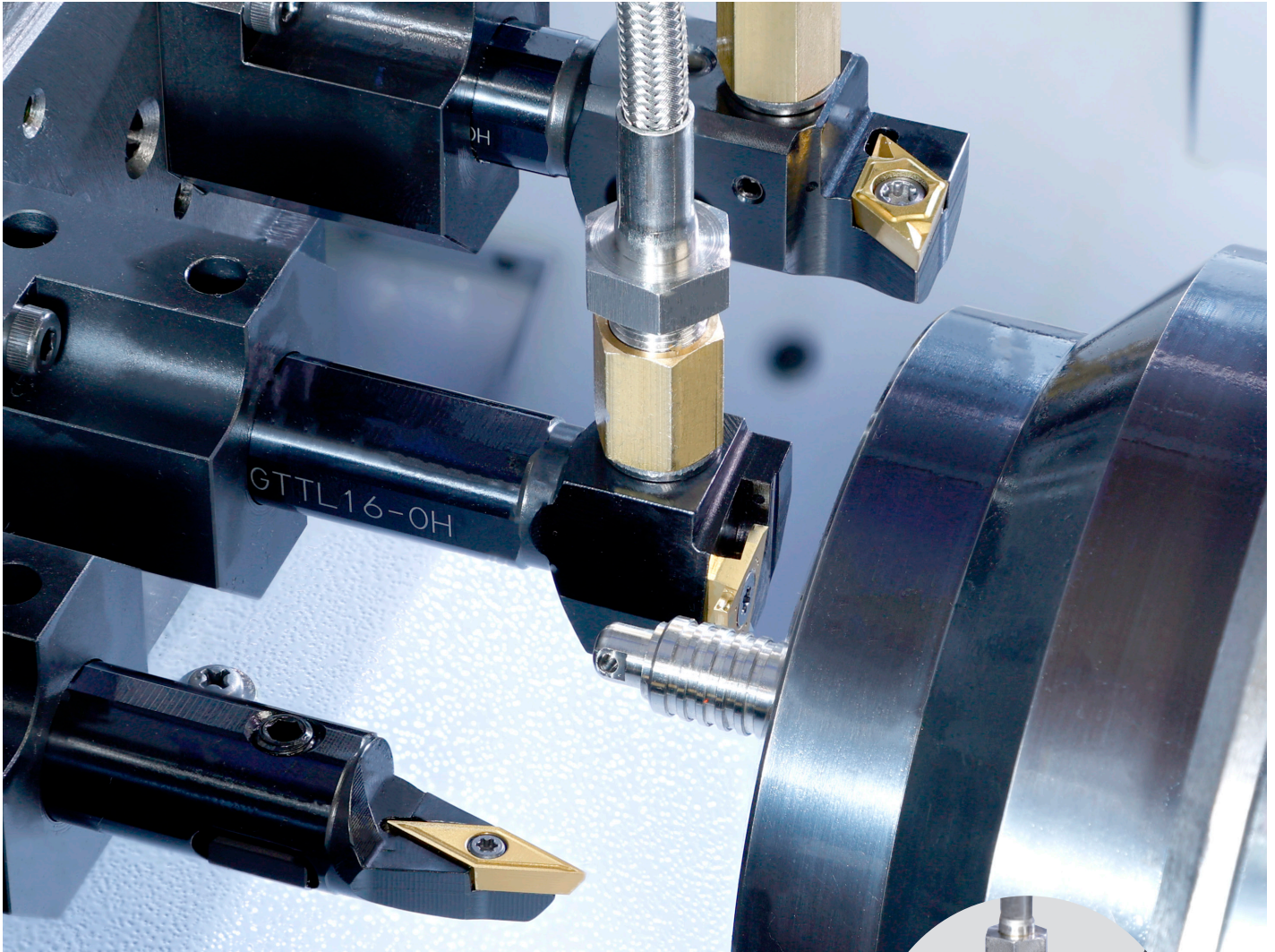

Internal coolant type grooving holder added to DS holder series.

💧 The internal coolant supply improves tool wear resistance and chip control.



CERtainly | but not only | *CERamics*
Outstanding solutions for demanding applications



Internal coolant type is now available in the DS holder for grooving

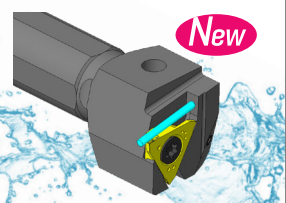
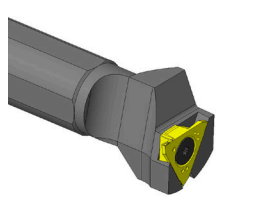

| Feature 1.

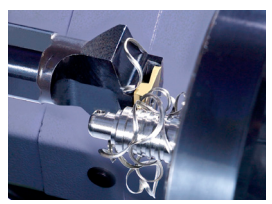
Improves chip control.

	External + Internal coolant	External coolant only
Holder type		
Chips		

| Feature 2.

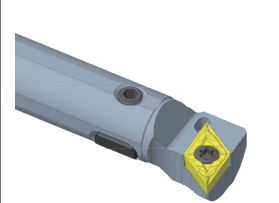
Reduces insert wear.

	External + Internal coolant	External coolant only
Holder type		
Lateral relief surface		

| Feature 3.

Centerline height can be easily adjusted with a wrench reducing setup time.

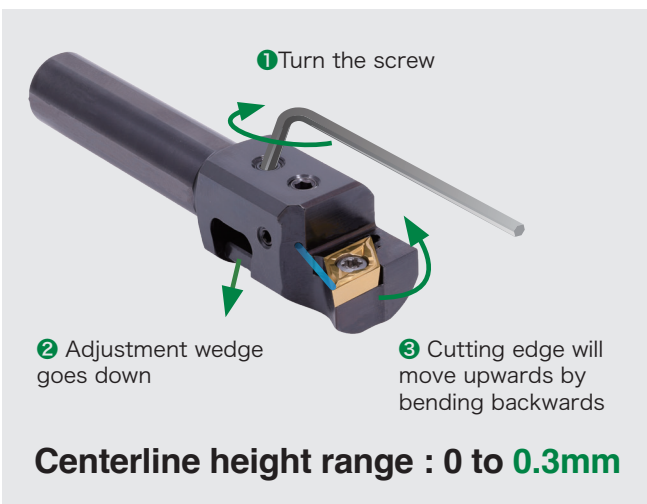

| How to use

* The insert moves in an upward direction only. (Loosen wedge screw before making any adjustments)

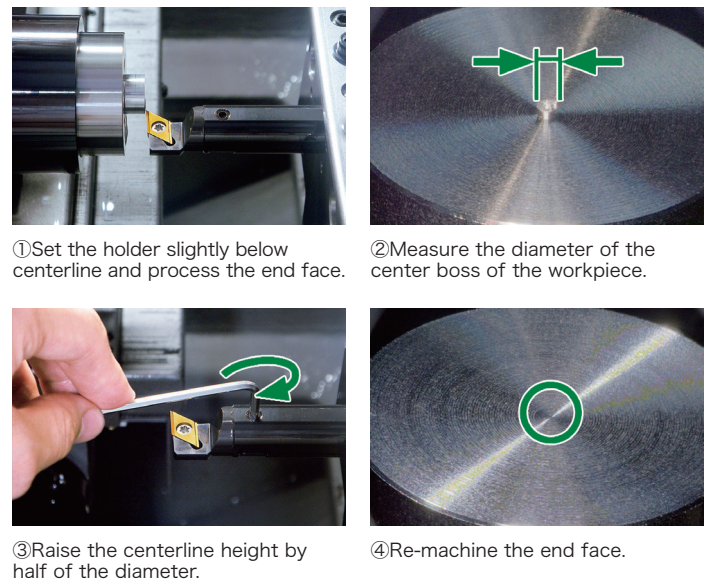

Lineup

Front Turning

DS-...-OH Clnternal coolant DS-...-ACH... Centerline height adjustment

<p>DS-PTX-ACH-OH</p> <p>100°</p> <p>→Next page</p>	<p>DS-PTX-ACH</p> <p>100°</p> <p>→Q54</p>	<p>DS-PTX</p> <p>100°</p> <p>→Q54</p>	<p>DS-SCL-ACH</p> <p>95°</p> <p>→Q15</p>	<p>DS-SCL</p> <p>95°</p> <p>→Q16</p>
<p>DS-SDU-ACH-OH</p> <p>93°</p> <p>→Next page</p>	<p>DS-SDU-ACH</p> <p>93°</p> <p>→Q27</p>	<p>DS-SDU</p> <p>93°</p> <p>→Q28</p>	<p>DS-SDX</p> <p>96°</p> <p>→Q30</p>	
<p>DS-SVX</p> <p>99°</p> <p>→Q46</p>	<p>DS-SVXP</p> <p>99°</p> <p>→Q46</p>	<p>DS-SVVPN-ACH</p> <p>72°30'</p> <p>→Q47</p>	<p>DS-SVVPN</p> <p>72°30'</p> <p>→Q48</p>	

Grooving

<p>DS-GTT-OH</p> <p>New →Next page</p>	<p>DS-GTT</p> <p>→T16</p>	<p>DS-FGV</p> <p>→T35</p>	<p>DS-GQGD</p> <p>New →See the brochure</p>
--	----------------------------------	----------------------------------	---

Threading

<p>DS-TTP</p> <p>→U18</p>	<p>DS-STT</p> <p>→U22</p>
----------------------------------	----------------------------------

Back Turning

<p>DS-TBP</p> <p>→R13</p>	<p>DS-GTT-OH</p> <p>New →Next page</p>	<p>DS-GTT</p> <p>→R27</p>
----------------------------------	--	----------------------------------

Boring

<p>DS-LBMB</p> <p>→V7</p>

Example

DS-SDX Toolholder type

Machining image

96°

→Q26

General catalog in 2023-2024 page

DS-SDU-ACH-OH Adjustable Centerline Height DS toolholder (Internal coolant type)

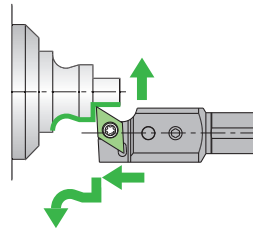
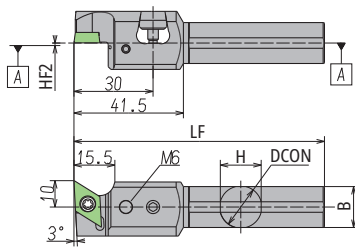

Spare Parts

Screw (for clamping)	LRIS-4*10
Screw (for wedge)	WS060419-004
Wedge	ACH-W18
Wrench (for clamping)	LLR-25S-20*65
Wrench (for wedge)	LW-3

This figure shows the left hand (L).

Note: Use the Right (R) or Non-hand (N) insert

Item Number	Hand	DCON mm	H mm	B mm	LF mm	HF2 mm	Insert
DS-SDUL16-11-ACH-OH	L	16.00	15.5	15.5	95	Adjustable Centerline Height TypeA(0→+0.2)	DC..11T3.. DC..11T3..WP
DS-SDUL19-11-ACH-OH	L	19.05	18	18	120		
DS-SDUL20-11-ACH-OH	L	20.00	19	19	120		
DS-SDUL22-11-ACH-OH	L	22.00	21	21	120		
DS-SDUL25-11MET-ACH-OH	L	25.00	24	24	150		
DS-SDUL25-11-ACH-OH	L	25.40	24	24	150		

DS-PTX-ACH-OH Adjustable Centerline Height DS toolholder (Internal coolant type)

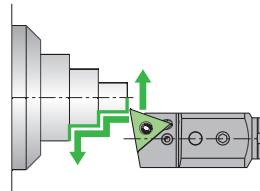
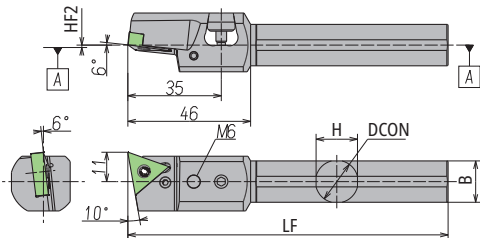

Spare Parts

Screw (for clamping)	LCS33
Screw (for wedge)	WS060419-004
Lever (for clamping)	LCL33N
Wedge	ACH-W18
Wrench (for clamping)	LW-2
Wrench (for wedge)	LW-3

This figure shows the left hand (L).

Note: Use the Right (R) or Non-hand (N) insert

Item Number	Hand	DCON mm	H mm	B mm	LF mm	HF2 mm	Insert
DS-PTXL16-33-ACH-OH	L	16.00	15.5	15.5	120	Adjustable Centerline Height TypeA(0→+0.2)	TN..1604..
DS-PTXL19-33-ACH-OH	L	19.05	18	18	120		
DS-PTXL20-33-ACH-OH	L	20.00	19	19	120		
DS-PTXL22-33-ACH-OH	L	22.00	21	21	120		
DS-PTXL25-33MET-ACH-OH	L	25.00	24	24	150		
DS-PTXL25-33-ACH-OH	L	25.40	24	24	150		

DS-GTT-OH (Internal coolant type)

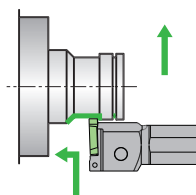
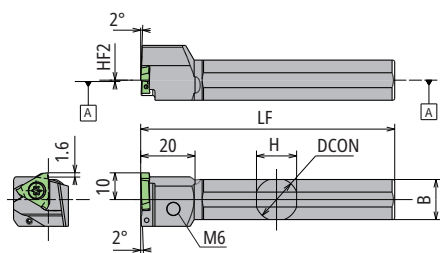

Spare Parts

Screw (for clamping)	LR-S-4*9
Wrench (for clamping)	RLR-20S

This figure shows the left hand (L).

Note: Use the Right (R) or Non-hand (N) insert

Item Number	Hand	DCON mm	H mm	B mm	LF mm	HF2 mm	Insert
DS-GTTL16-OH	L	16.00	15	15	95	0	TBMH32.. GT..32..
DS-GTTL19-OH	L	19.05	18	18	120		
DS-GTTL20-OH	L	20.00	19	19	120		
DS-GTTL22-OH	L	22.00	21	21	120		
DS-GTTL25MET-OH	L	25.00	24	24	150		
DS-GTTL25-OH	L	25.40	24	24	150		



NTK CUTTING TOOLS JAPAN
2808 Iwazaki, Komaki, Aichi 485-8510, Japan



www.ntkcuttingtools.com/global/contact/

