

The Front Max

For External turning | CNC automatic lathes

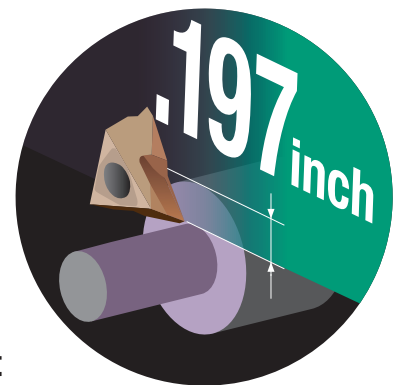
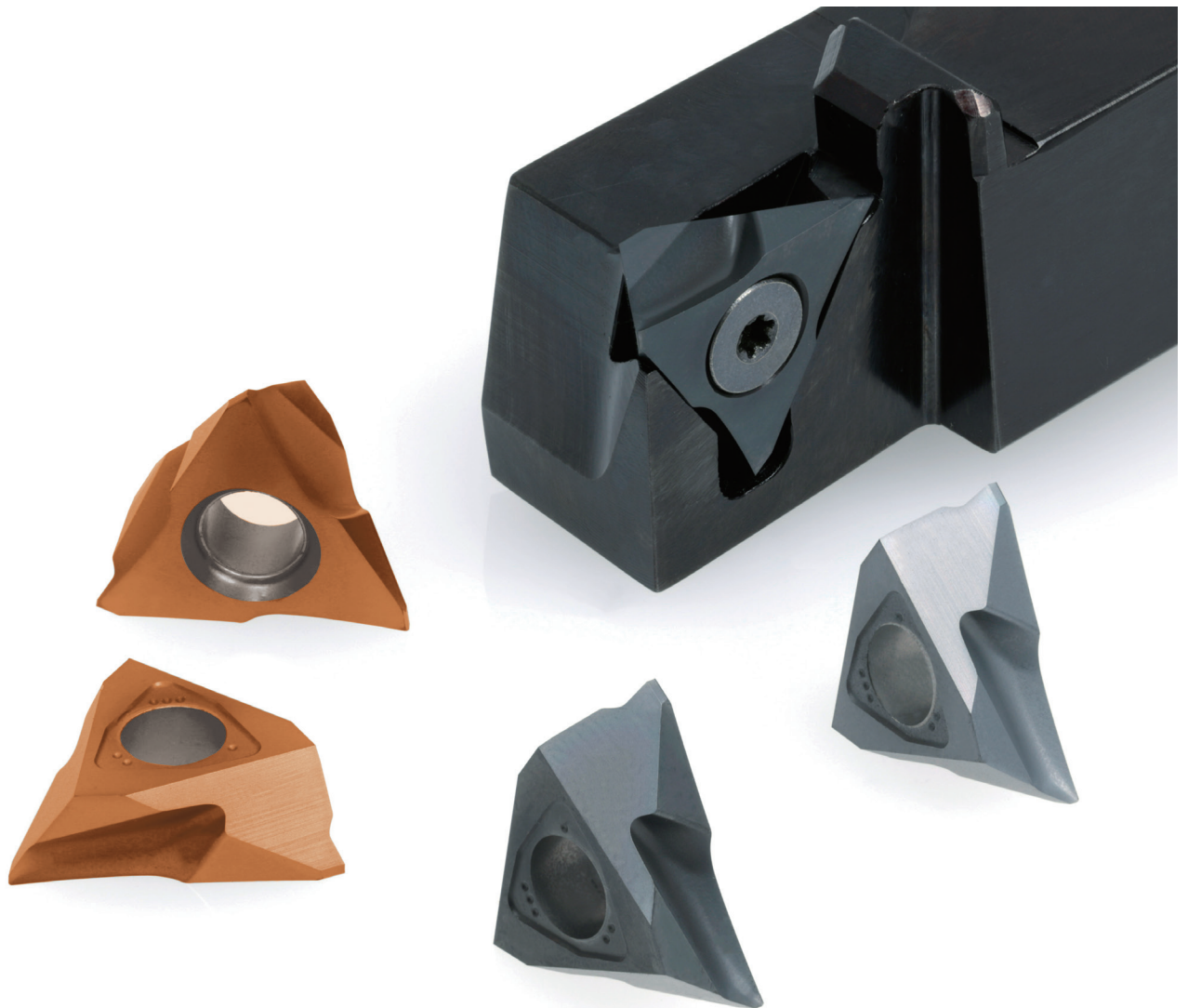

Single pass machining of up to .197" (5.0mm) depth of cut

Significant reduction in cycle time due to large depth of cut capability

CERTainly | but not only | *CERamics*
Outstanding solutions for demanding applications

Miniature Tool Line

SINGLE PASS TURNING UP TO .197" (5.0MM) DEPTH OF CUT

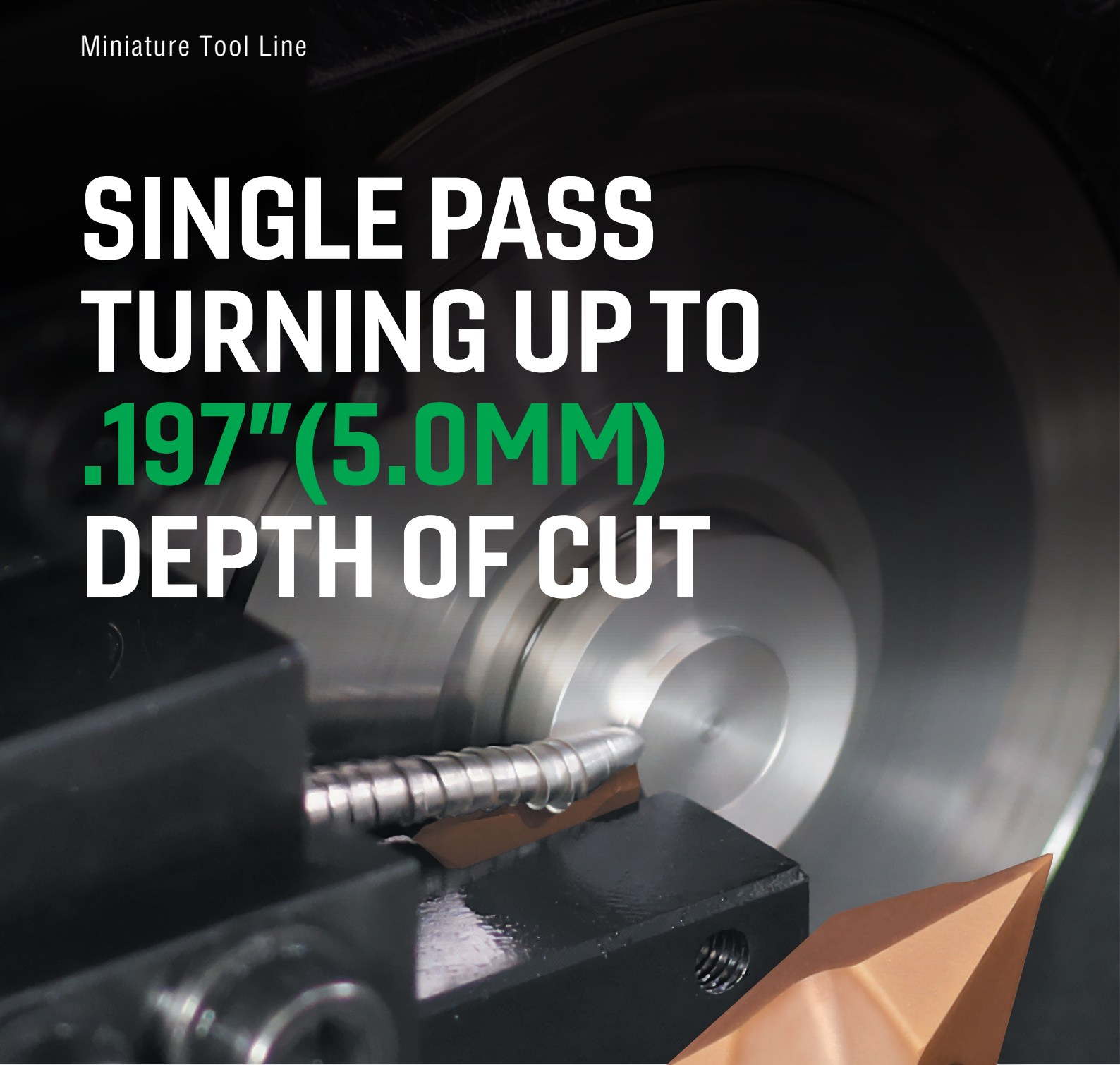

Dedicated holder

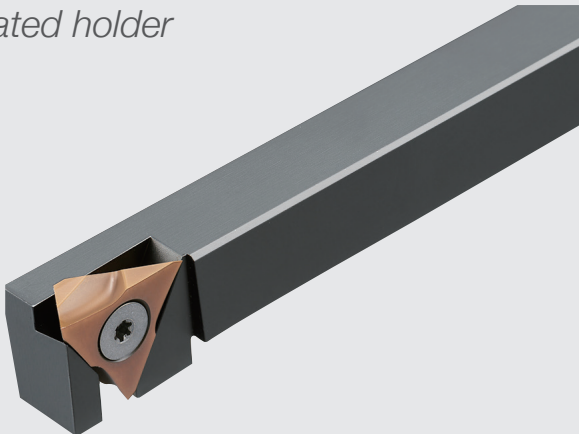

The Front Max

Maximum depth of cut .197"(5.0mm)
 Single pass machining reduces cycle time.
 Fewer machining passes reduce insert wear.
 Tool life can be extended.

Uniquely Designed Chipbreaker Achieves Excellent Chip Control And Machined Surfaces.

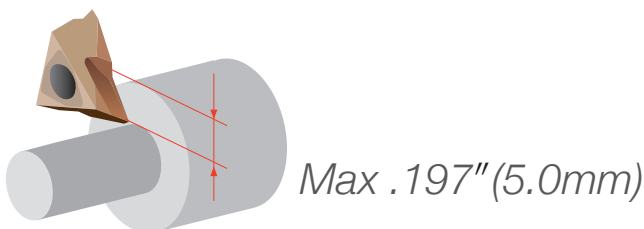

FUNCTIONING RANGE

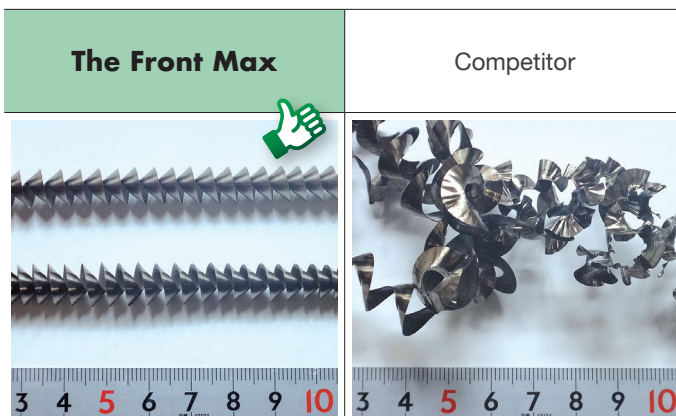
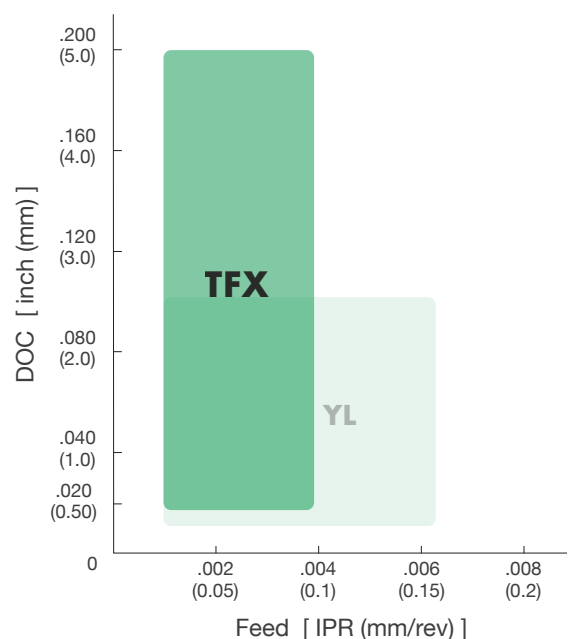

material: AISI304
 ap.**0.197inch (5.0mm)** vc=260SFM (80m/min)
 f=.001IPR (0.03mm/rev) WET



Front Turning Operations

TF.. series/Toolholder

Inch

TFT-OH3 [93°] Direct connect coolant port 3-hole type The Front Max.

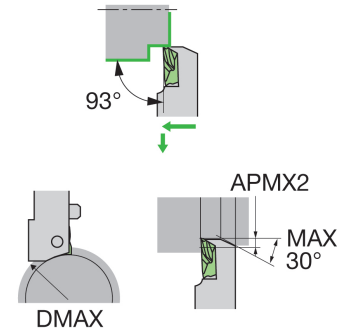
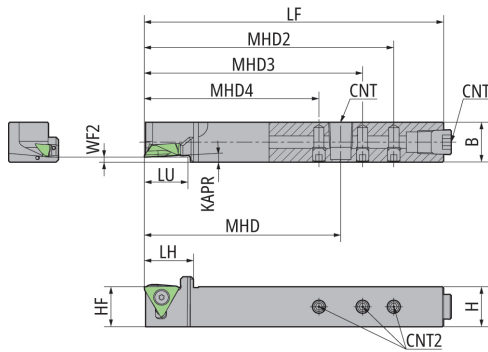

● Diagram shows right-hand tool

[Workpiece shape restrictions during machining]
 DMAX: Max. bar stock diameter during APMX2 max DOC
 APMX2: Max depth of cut

Item Number	Hand	DMAX	APMX2	B	CNT	CNT2	H	HF	KAPR	LF	LH	LU	MHD	MHD2	MHD3	MHD4	WF2	Insert Gage	
		inch	inch	inch			inch	inch	°	inch	inch	inch	inch	inch	inch	inch	inch	inch	TFX33..
TFTR10X-IN-OH3	R	1.575	.098	5/8	NPT1/8	M5	5/8	5/8	3	4.724	.778	.709	3.100	3.937	3.445	2.756	.079	TFX33..	TF33..

Spare Parts

Item Number	Clamp screw	Screw (for CNT)	Screw (for CNT2)	Wrench (for Clamp screw)	Wrench (for CNT2)
TFTR10X-IN-OH3	LR-S-4*10PW	SPNPT1/8	SS0505SC	CLR-15S	LW-2.5

TFT-OH2 [93°] Direct connect coolant port 1-hole type The Front Max.

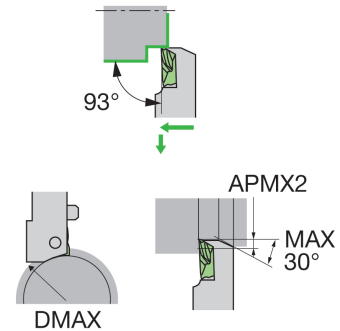
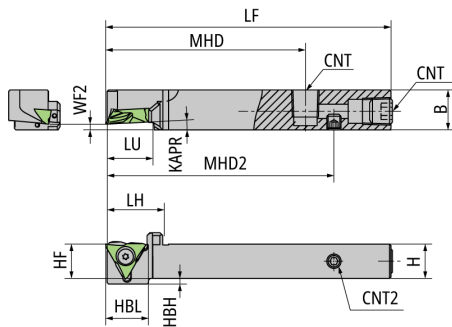

● Diagram shows right-hand tool

[Workpiece shape restrictions during machining]
 DMAX: Max. bar stock diameter during APMX2 max DOC
 APMX2: Max depth of cut

Item Number	Hand	DMAX	APMX2	B	CNT	CNT2	H	HBH	HBL	HF	KAPR	LF	LH	LU	MHD	MHD2	WF2	Insert Gage	
		inch	inch	inch			inch	inch	inch	inch	inch	inch	°	inch	inch	inch	inch	inch	TFX33..
TFTR06H-IN-OH2	R	.787	.098	.551	M6*1	M5	3/8	.157	.591	3/8	3	3.937	.787	.591	2.756	3.150	.079	TFX33..	TF33..
TFTR08H-IN-OH2	R	1.181	.098	.551	NPT1/8	M5	1/2	.079	.591	1/2	3	3.937	.787	.591	2.756	3.150	.079	TFX33..	TF33..
TFTR10X-IN-OH2	R	1.575	.098	5/8	NPT1/8	M5	5/8	-	-	5/8	3	4.724	.787	.689	2.756	3.937	.079	TFX33..	TF33..

Spare Parts

Item Number	Clamp screw	Screw (for CNT)	Screw (for CNT2)	Wrench (for Clamp screw)	Wrench (for CNT2)
TFTR06H-IN-OH2	LR-S-4*10PW	SS0605SC	SS0505SC	CLR-15S	LW-2.5
TFTR08H-IN-OH2	LR-S-4*10PW	SPNPT1/8	SS0505SC	CLR-15S	LW-2.5
TFTR10X-IN-OH2	LR-S-4*10PW	SPNPT1/8L	SS0505SC	CLR-15S	LW-2.5

TFT [93°]

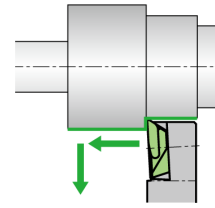
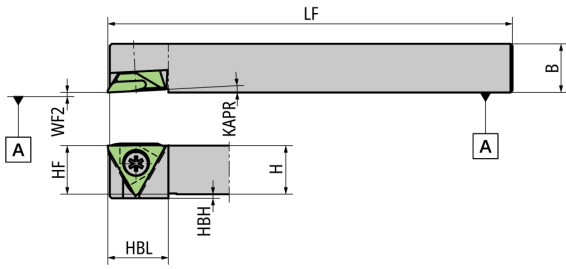

● Diagram shows right-hand tool

Item Number	Hand	B	H	HBH	HBL	HF	KAPR	LF	WF2	Insert Gage	
		inch	inch	inch	inch	inch	°	inch	inch	TFX33..	TF33..
TFTR06-IN	R	3/8	3/8	.118	.591	3/8	3	4.724	.000	TFX33..	TF33..
TFTR08-IN	R	1/2	1/2	.039	.591	1/2	3	4.724	.000	TFX33..	TF33..

Spare Parts

Item Number	Clamp screw	Wrench (for Clamp screw)
TFTR06-IN	LR-S-4*10PW	CLR-15S
TFTR08-IN	LR-S-4*10PW	CLR-15S

TF.. series/Inserts

TFX The Front Max

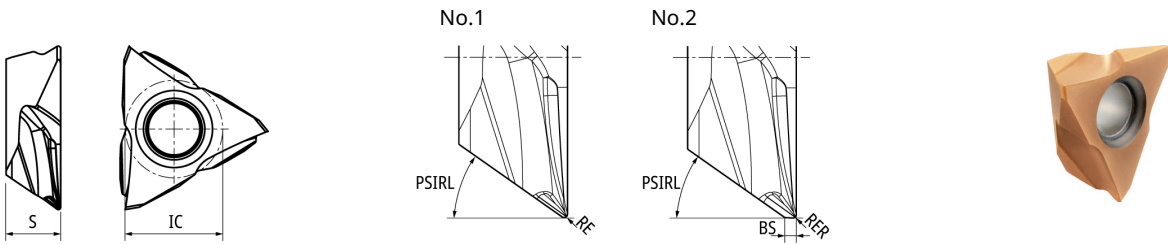

● Diagram shows right-hand tool
All angles shown are obtained when insert is set in the holder.

Figure	Item Number	Hand	Wiper	APMX	IC	S	BS	PSIRL	RE	RER	Carbide	
				inch	inch	inch	inch	°	inch	inch	PVD	
											DM4	ST4
1	TFX3301MR	R	-	.197	3/8	3/16	-	32	.003	-	●	●
1	TFX3302MR	R	-	.197	3/8	3/16	-	32	.007	-	●	●
1	TFX3304MR	R	-	.197	3/8	3/16	-	32	.015	-	●	●
2	TFX3301MRW	R	Straight	.197	3/8	3/16	.020	32	-	.003	●	●
2	TFX3302MRW	R	Straight	.197	3/8	3/16	.020	32	-	.007	●	●
2	TFX3304MRW	R	Straight	.197	3/8	3/16	.020	32	-	.015	●	●

Note: Initial dimensional adjustments may be required depending on the machining condition.

Front Turning Operations TF.. series/Toolholder

TFT-OH3 [93°] Direct connect coolant port 3-hole type The Front Max.

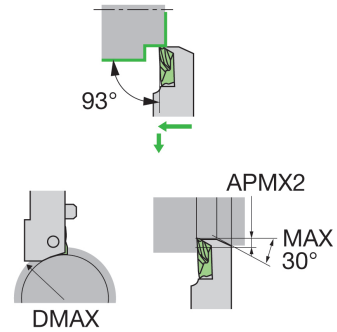
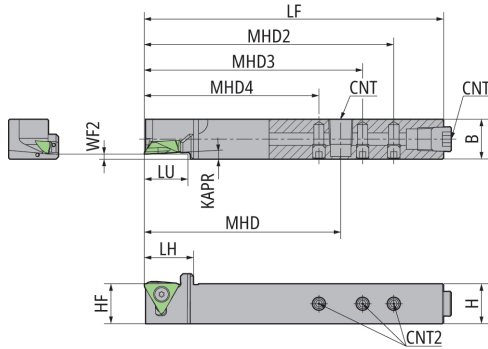

● Diagram shows right-hand tool

[Workpiece shape restrictions during machining]
DMAX: Max. bar stock diameter during APMX2 max DOC
APMX2: Max depth of cut

Item Number	Stock	Hand	DMAX	APMX2	B	CNT	CNT2	H	HF	KAPR	LF	LH	LU	MHD	MHD2	MHD3	MHD4	WF2	Insert Gage		
			mm	mm	mm			mm	mm	mm	mm	mm	°	mm	mm	mm	mm	mm	mm	mm	mm
TFTR1616X-OH3	Blue	Red	R	40	2.5	16	Rc1/8	M5	16	16	3	120	19.75	18	78.75	100	87.5	70	2	TFX33..	TF33..

Spare Parts

Item Number	Clamp screw	Screw (for CNT)	Screw (for CNT2)	Wrench (for Clamp screw)	Wrench (for CNT2)
TFTR1616X-OH3	LR-S-4*10PW	SPR1/8L	SS0505SC	CLR-15S	LW-2.5

TFT-OH2 [93°] Direct connect coolant port 1-hole type The Front Max.

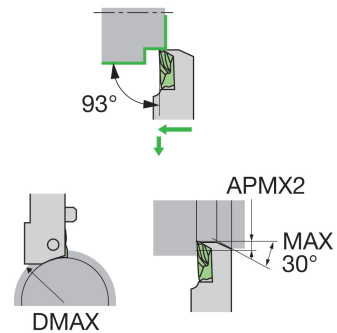
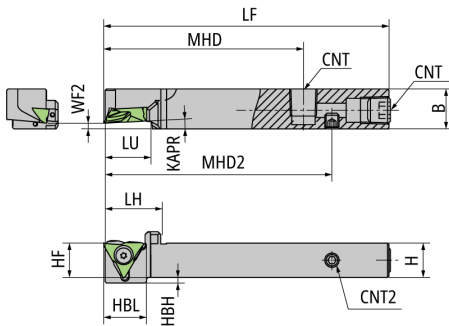

● Diagram shows right-hand tool

[Workpiece shape restrictions during machining]
DMAX: Max. bar stock diameter during APMX2 max DOC
APMX2: Max depth of cut

Item Number	Hand	DMAX	APMX2	B	CNT	CNT2	H	HBH	HBL	HF	KAPR	LF	LH	LU	MHD	MHD2	WF2	Insert Gage	
		mm	mm	mm			mm	mm	mm	mm	mm	mm	°	mm	mm	mm	mm	mm	mm
TFTR1014H-OH2	R	20	2.5	14	M6*1	M5	10	4	15	10	3	100	20	15	70	80	2	TFX33..	TF33..
TFTR1214H-OH2	R	30	2.5	14	Rc1/8	M5	12	2	15	12	3	100	20	15	70	80	2	TFX33..	TF33..
TFTR1616X-OH2	R	40	2.5	16	Rc1/8	M5	16	-	-	16	3	120	20	17.5	70	80	2	TFX33..	TF33..

Spare Parts

Item Number	Clamp screw	Screw (for CNT)	Screw (for CNT2)	Wrench (for Clamp screw)	Wrench (for CNT2)
TFTR1014H-OH2	LR-S-4*10PW	SS0605SC	SS0505SC	CLR-15S	LW-2.5
TFTR1214H-OH2	LR-S-4*10PW	SPR1/8	SS0505SC	CLR-15S	LW-2.5
TFTR1616X-OH2	LR-S-4*10PW	SPR1/8L	SS0505SC	CLR-15S	LW-2.5

TFT [93°]

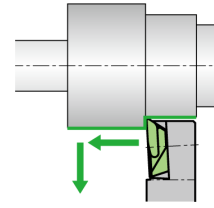
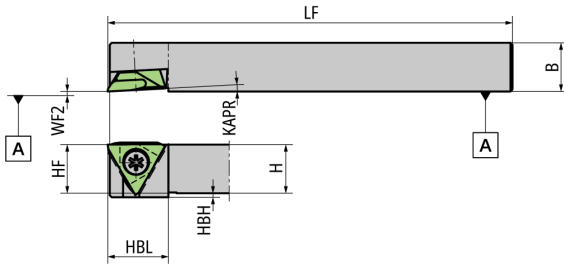

● Diagram shows right-hand tool

Item Number	Hand	B	H	HBH	HBL	HF	KAPR	LF	WF2	Insert Gage	
		mm	mm	mm	mm	mm	°	mm	mm	TFX33..	TF33..
TFTR10	R	10	10	3	15	10	3	120	0	TFX33..	TF33..
TFTR12	R	12	12	1	15	12	3	120	0	TFX33..	TF33..
TFTR16	R	16	16	-	-	16	3	120	0	TFX33..	TF33..
TFTR20	R	20	20	-	-	20	3	120	0	TFX33..	TF33..

Spare Parts

Item Number	Clamp screw	Wrench (for Clamp screw)
TFTR10	LR-S-4*10PW	CLR-15S
TFTR12	LR-S-4*10PW	CLR-15S
TFTR16	LR-S-4*10PW	CLR-15S
TFTR20	LR-S-4*10PW	CLR-15S

TF.. series/Inserts

TFX The Front Max

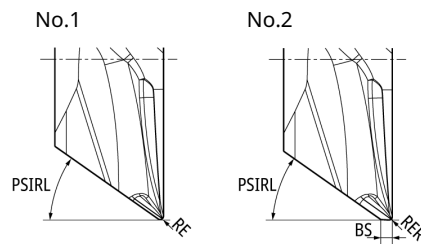
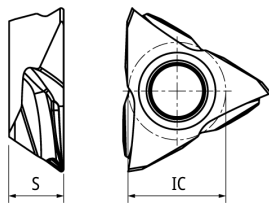

● Diagram shows right-hand tool
All angles shown are obtained when insert is set in the holder.

Figure	Item Number	Hand	Wiper	APMX	IC	S	BS	PSIRL	RE	RER	Carbide PVD	
				mm	mm	mm	mm	°	mm	mm	DM4	ST4
1	TFX3301MR	R	-	5	9.525	4.76	-	32	0.08	-	●	●
1	TFX3302MR	R	-	5	9.525	4.76	-	32	0.18	-	●	●
1	TFX3304MR	R	-	5	9.525	4.76	-	32	0.38	-	●	●
2	TFX3301MRW	R	Straight	5	9.525	4.76	0.5	32	-	0.08	●	●
2	TFX3302MRW	R	Straight	5	9.525	4.76	0.5	32	-	0.18	●	●
2	TFX3304MRW	R	Straight	5	9.525	4.76	0.5	32	-	0.38	●	●

Tungaloy-NTK America, Inc.

3726 N. Ventura Drive
Arlington Heights
IL 60004, U.S.A.
Phone: +1-888-554-8394
Fax: +1-888-554-8392
www.tungaloy.com/us
https://www.ntkcuttingtools.com

Tungaloy Canada

432 Elgin St. Unit 3, Brantford
Ontario N3S 7P7, Canada
Phone: +1-519-758-5779
Fax: +1-519-758-5791
www.tungaloy.com/ca

Tungaloy-NTK de Mexico S.A.

C/ Los Arellano 113
Parque Industrial Siglo XXI
Aguascalientes, AGS
Mexico 20290
Phone: +52-449-929-5410
Fax: +52-449-929-5411
www.tungaloy.com/mx
https://www.ntkcuttingtools.com/mx/

Tungaloy-NTK do Brasil Ltda.

Avd. Independencia N4158
Residencial Flora
13280-000 Vinhedo
São Paulo, Brazil
Phone: +55-19-38262757
Fax: +55-19-38262757
www.tungaloy.com/br
https://www.ntkcuttingtools.com/br/

Tungaloy Hungary Kft

Erzsébet királyné útja 125
H-1142 Budapest, Hungary
Phone: +36 1 781-6846
Fax: +36 1 781-6866
www.tungaloy.com/hu

Tungaloy Turkey

Serifali Mah. bayraktar
Bulvari Kule Sk. No:26
34775 Umraniye / Istanbul / Turkey
Phone: +90 216 540 04 67
Fax: +90 216 540 04 87
www.tungaloy.com/tr

Tungaloy Benelux b.v.

Tjalk 70
NL-2411 NZ Bodegraven Netherlands
Phone: +31 172 630 420
Fax: +31 172 630 429
www.tungaloy.com/nl

Tungaloy Croatia

Ulica bana Josipa Jelačića 87,
10430 Samobor, Croatia
Phone: +385 1 3326 604
Fax: +385 1 3327 683
www.tungaloy.com/hr

NTK Cutting Tools (Shanghai) Co., Ltd

Room 103, Building C, No. 7666 Zhong-
chun Road, Minhang District, Shanghai,
200131, China
Phone: +86-21-64788878
Fax: +86-21-64788879
www.ntkcuttingtools.com/zh-hans/

Tungaloy-NTK Germany GmbH

Katzbergstr. 3a
D-40764 Langenfeld, Germany
Phone: +49-2173-90420-0
Fax: +49-2173-90420-19
www.tungaloy.com/de
https://www.ntkcuttingtools.com/de/

Tungaloy France S.A.S.

Les Fjords
19 avenue de Norvège
91140 Villebon Sur Yvette, France
Phone: +33-1-6486-4300
Fax: +33-1-6907-7817
www.tungaloy.com/fr

Tungaloy Italia S.r.l.

Viale Sarca 336/Edificio 13
20126 Milano, Italy
Phone: +39-02-252012-1
Fax: +39-02-252012-65
www.tungaloy.com/it

Tungaloy Czech s.r.o

Turanka 1583/115g,
627 00 Brno, Czech Republic
Phone: +420-532 123 391
www.tungaloy.com/cz

Tungaloy Ibérica S.L.

C/Miquel Servet, 43B, Nau 7
Pol. Ind. Bufalvent
ES-08243 Manresa (BCN), Spain
Phone: +34 93 113 1360
Fax: +34 93 876 2798
www.tungaloy.com/es

Tungaloy-NTK Cutting Tools (Thailand) Co.,Ltd.

Interlink tower 4th Fl.
1858/5-7 Bangna-Trad Road
km.5 Bangna, Bangna, Bangkok 10260
Thailand
Phone: +66-2-751-5711
Fax: +66-2-751-5715
www.tungaloy.com/th
https://www.ntkcuttingtools.com/th/

Tungaloy Cutting Tools (Taiwan) Co.,Ltd.

9F. No.293, Zhongyang Rd,
Xinzhuang Dist, New Taipei City,
24251 Taiwan
Phone: +886-2-8521-9986
Fax: +886-2-8521-8935
www.tungaloy.com/tw

Tungaloy Singapore (Pte.), Ltd.

62 Ubi Road 1,
#08-09 Oxley BizHub 2
Singapore 408734
Phone: +65-6391-1833
Fax: +65-6299-4557
www.tungaloy.com/sg

Tungaloy-NTK Vietnam LLC

3rd Floor, Licogi 13 Tower,
164 Khuat Duy Tien, Nhan Chinh, Thanh
Xuan District,
Hanoi, Vietnam
Phone: +84 24 63282086
www.tungaloy.com/vn

Tungaloy Scandinavia AB

Bultgatan 38, 442 40
Kungälv, Sweden
Phone: +46-462119200
Fax: +46-462119207
www.tungaloy.com/se

Tungaloy Rus, LLC

Andropova avenue, h.18/7,
11 floor, office 3, 115432,
Moscow, Russia
Phone: +7-499-683-01-80
Fax: +7-499-683-01-81
www.tungaloy.com/ru

Tungaloy Polska Sp. z o.o.

Ul. Irysowa 1, 55-040 Bielany
Wrocławskie, Poland
Phone: +48 607 907 237
www.tungaloy.com/pl

Tungaloy-NTK U.K. Ltd

Suite 3, Pioneer House, Mill Street,
Cannock, WS11 0EF, UK
Phone: +44 121 4000 231
Fax: +44 121 270 9694
www.tungaloy.com/uk
https://www.ntkcuttingtools.com/uk/

Tungaloy India Pvt. Ltd.

One International Center,
Unit # 902-A, 9th Floor,
Tower 1, Senapati Bapat Marg,
Elphinstone Road (West),
Mumbai -400013, India
Phone: +91-22-6124-8804
Fax: +91-22-6124-8899
www.tungaloy.com/in

Tungaloy-NTK Korea Ltd

1040 Gachang-ro, Gachang-myeon,
Dalseong-gun, Daegu, 42936, Korea
Phone: +82-53-760-7698
Fax: +82-53-768-9912
www.tungaloy.com/kr

Tungaloy Malaysia Sdn Bhd

50 K-2, Kelana Mall, Jalan
SS6/14, Kelana Jaya, 47301
Petaling Jaya, Selangor Darul Ehsan
Malaysia
Phone: +603-7805-3222
Fax: +603-7804-8563
www.tungaloy.com/my

Tungaloy Australia Pty Ltd

Unit 68 1470 Ferntree Gully Road
Knoxfield 3180 Victoria, Australia
Phone: +61-3-9755-8147
Fax: +61-3-9755-6070
www.tungaloy.com/au

PT. Tungaloy Indonesia

Kompleks Grand Wisata Block AA-10
No.3-5 Cibitung
Bekasi 17510, Indonesia
Phone: +62-21-8261-5808
Fax: +62-21-8261-5809
www.tungaloy.com/id